

AKZ692/..-2.54-V-GREEN



Technical Data

Wire Sizes		Insulating Material	
Solid min	0.14 mm ²	Material	PA 6.6
Solid max	0.75 mm ²	Flammability Class	UL 94 V-0
Stranded (flexible) min	0.14 mm ²	Temperatures	
Stranded (flexible) max	0.75 mm ²	Operating Temperature	-30 °C - 105 °C
Stranded with Ferrule min	0.14 mm ²	Wave Soldering Process	
Stranded with Ferrule max	0.34 mm ²	Soldering Temperature, recommended	265 °C
Dimensions		Peak Soldering Time, recommended	3 s / 10 s
Stripped Length	4.0 mm	Reflow Process	
PCB Hole Diameter	1.3 mm	Soldering Temperature, recommended	-
Materials		Peak Soldering Time, recommended	-
Clamp	Brass		
Screw	Steel		
Solder Tag	Brass		

Colours

GREEN, RAL 6018
 LIGHT GREEN, similar RAL 6018

Colours according to RAL, there may be variations on colour due to production conditions. Special colours on request.

Order Data (Spacing 2.54 mm)

Poles	Width (mm)	Article Designation	Article Number	PU
2	5.48	AKZ692/2-2.54-V-GREEN	50692020021E	100
3	8.02	AKZ692/3-2.54-V-GREEN	50692030021E	100
4	10.56	AKZ692/4-2.54-V-GREEN	50692040021E	100
5	13.10	AKZ692/5-2.54-V-GREEN	50692050021E	100
6	15.64	AKZ692/6-2.54-V-GREEN	50692060021E	100
7	18.18	AKZ692/7-2.54-V-GREEN	50692070021E	100
8	20.72	AKZ692/8-2.54-V-GREEN	50692080021E	100
9	23.26	AKZ692/9-2.54-V-GREEN	50692090021E	100
10	25.80	AKZ692/10-2.54-V-GREEN	50692100021E	100
11	28.34	AKZ692/11-2.54-V-GREEN	50692110021E	100
12	30.88	AKZ692/12-2.54-V-GREEN	50692120021E	100
13	33.42	AKZ692/13-2.54-V-GREEN	50692130021E	100
14	35.96	AKZ692/14-2.54-V-GREEN	50692140021E	100
15	38.50	AKZ692/15-2.54-V-GREEN	50692150021E	100
16	41.04	AKZ692/16-2.54-V-GREEN	50692160021E	100
17	43.58	AKZ692/17-2.54-V-GREEN	50692170021E	100
18	46.12	AKZ692/18-2.54-V-GREEN	50692180021E	100
19	48.66	AKZ692/19-2.54-V-GREEN	50692190021E	100
20	51.20	AKZ692/20-2.54-V-GREEN	50692200021E	100
21	53.74	AKZ692/21-2.54-V-GREEN	50692210021E	100
22	56.28	AKZ692/22-2.54-V-GREEN	50692220021E	100
23	58.82	AKZ692/23-2.54-V-GREEN	50692230021E	100
24	61.36	AKZ692/24-2.54-V-GREEN	50692240021E	100

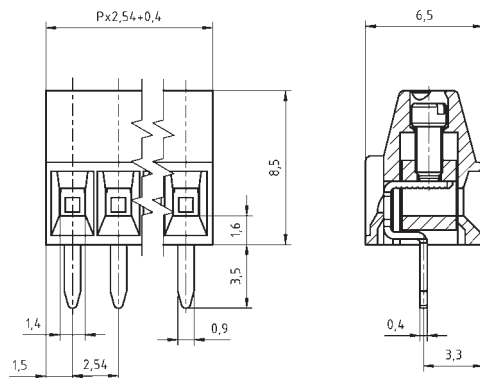

Ratings



Usegroup	B	C	D		
Rated Voltage	150 V	-	-	130 V	
Rated Current	7 A	-	-	9 A	
Rated Wire Size				min	max
	solid	AWG 30-18	-	0.14 mm ²	0.75 mm ²
	stranded	AWG 30-18	-	0.14 mm ²	0.75 mm ²
Torque	0.10 Nm	-	-	0.10 Nm	
Screw Size	M1.6	-	-	M1.6	
Test Voltage	1.3 kV	-	-	1.25 kV	